

Cable Operated Dual Flush Concealed Cistern

FITTING INSTRUCTIONS

Please ensure these instructions are followed carefully – if you are unsure about any aspect of the installation, please consult a Qualified Installer. In the event of any problem with the function of this equipment, please check installation before contacting your supplier.

Before commencing installation, please check that all of the following items have been supplied, and you are thoroughly familiar with these instructions.

CONTENTS IN CARTON

Cistern Lid
Cistern Body
Flushpipe
Inlet Valve

Outlet Valve
Wall Hanging Bracket
Fixings Pack

All parts are quantity 1 unless stated otherwise

INSTALLATION OF EQUIPMENT

Do not use mole grips on plastic nuts

Do not use a sealing compound as damage may occur to plastic components.

Do not overtighten plastic nuts

The fixings supplied with this cistern will NOT suit every type of material or construction

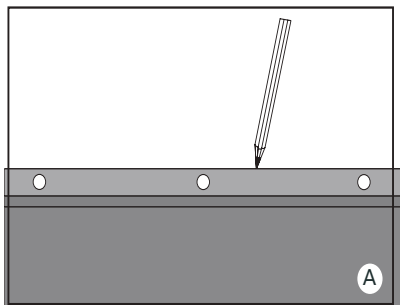

Line markings of cistern as drawn in picture 'A'

CISTERN BODY

Note: Maximum dimensions of flushpipe. Establish where cistern is to be located relative to the WC pan. Hold cistern in place, ensure cistern is level using a spirit level, and mark where the cistern is to be located, as shown in picture A. Mark top and sides of cistern and fit the wall hung fixing bracket to the dimensions shown below.

Using a screwdriver, lock the wall hung fixing bracket into position using screws provided, as shown in picture 'B'

When fitting wall hung fixing bracket, ensure that the arrow indicated points towards wall/cabinet

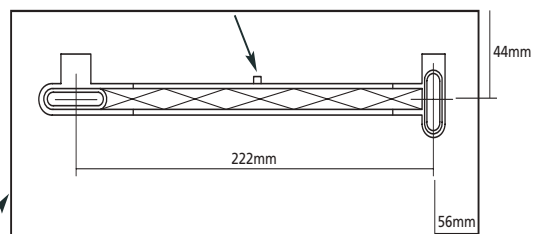
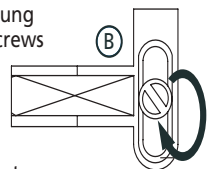



Place conical sealing washer over threads, insert through hole in cistern secure in place using the slip ring and 1/2" back-nut supplied. Secure hand tight plus half turn with a spanner, tighten further if necessary.

Do not use mole grips on plastic nuts and do not use sealing compound, as damage may occur to plastic components.

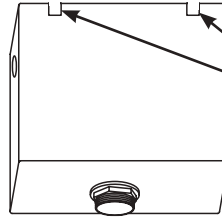

PUT CABLE INTO SLOT ON CISTERN

OUTLET VALVE

Insert threaded section of the valve into the cistern, with base seal on the inside, secure with back-nut hand tight, tighten further 1/2 turn using a spanner, check for leaks, tighten further if necessary.

Place the coupling nut on the flushpipe then place the seal as shown, the seal must be no more than 35mm onto the flushpipe, secure the flushpipe onto the valve, hand tight, check for leaks.

Fit the finned gasket as shown, insert into WC pan and ensure no leaks.

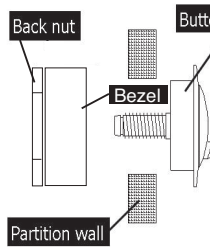
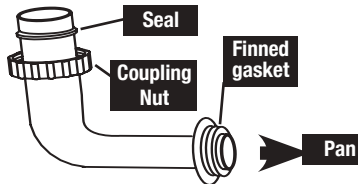

Insert the button assembly through the aperture and secure in place, hand tight using the back-nut provided, do not overtighten as it could cause the button to stick.

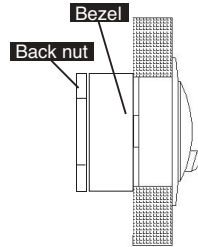

Connect the cable assembly to the button assembly by inserting the threads, then firmly clicking the slide across, please ensure the route of the cable is not kinked.

Final Commissioning

Ensure that all pipework is clear of debris before connecting to the inlet valve.

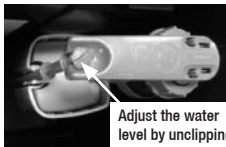

Adjust the water level by unclipping the red rod and move the cup and float up or down and then clip the red rod back into place.

Once installation is complete, turn the water supply and allow the cistern to fill. Adjust the water level by unclipping the red rod and moving the cup and float up or down and then clip the red rod back into place. The water line needs to be set to the 6 litre water line marked in cistern.

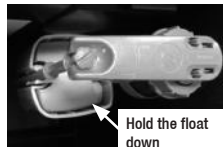

Hold the float down

Hold the inlet valve float down, causing the cistern to internally overflow, ensure overflow is capable of discharging the incoming water, if necessary reduce flow by partially closing the isolation valve (not supplied).

Code No.	PMCON01
Version No.	02
Date	15/04/2016